

MULTIFRESH® NEXT SL



The propane blast chiller, ecological and completely customizable according to the needs of each professional choosing functions, type of performance, size of the display and the most useful features for its use.

The MultiFresh® Next blast chiller has up to 12 functions and 150 cycles selected for you by Irinox to preserve the product freshness longer.

Yield

	Turbo	
Fast cooling (+90/+3 °C)	40 kg	
Quick freezing (+90/-18 °C)	40 kg	

*Tests carried out in compliance with the Irinox procedure using 5-cm thick beef

Capacity

Number of trays: 8 x GN 2/1 | with Double MultiRack 14 x GN1/1 (H= 20 mm)

Number of trays: 5 x GN 2/1 | with Double MultiRack 8 x GN1/1 (H= 40 mm)

Number of trays: 4 GN 2/1 | with Double MultiRack 6 x GN1/1 (H= 65 mm)

Standard construction details

- Door opening on the left with hinges on the left.
- Patented concealed hinges.
- Full height door with double bevelled side edges.
- Low hinge with integrated door stop with 150° opening to avoid collisions between side-by-side equipment.
- Magnetic and slow closing of the door.
- Equipped with 10-chamber gasket designed for high and low temperatures.
- Core probe with 3 detection points with quick screw connector, anti-corrosion, watertight IP67.
- Large magnetic flat surface (400x150 mm) to fix the core probe.
- Easy removal and cleaning of the condenser filter thanks to the tilting grill.
- Ergonomic and robust handle made of steel.
- AISI 304 stainless steel internal and external material.
- Built-in air condensation.
- R290 coolant gas.
- MultiRack®, the patented adjustable tray holder that doubles the number of trays for each model and improves air circulation inside the blast chiller.
- 5 pairs of guides included.
- 4 adjustable feet H 80-115 mm.
- WIFI module included for the HACCP report download.

Item No.:

Qty.:

Project:

Operation

2 available configurations:

Essential This is the basic configuration that includes the most known functions of the blast chiller: cooling, rapid freezing, cold storage and non-stop cooling/freezing; regardless of the product introduction temperature, it always guarantees excellent results in terms of quality and uniformity of temperature in the cell.

Excellence The multi-function configuration including 12 functions. In addition to the cold functions present in the Essential configuration, you will find: hot preservation, defrosting, ready-to-serve, low-temperature cooking, chocolate melting, leavening, pasteurization and drying.

- MultiFresh® Next's cooling cycles lower to +3°C the core temperature of the food, introduced at any temperature, even as soon as it is out of the oven, and quickly cross the band of maximum bacterial proliferation, the cause of their natural ageing.
- MultiFresh® Next's freezing cycles transform the water contained in food into microcrystals that preserve its structure and quality for longer.
- Automatic recognition of manual work mode (timed) or automatic mode (with probe).

Available performance level

Turbo: this performance guarantees the cooling and freezing capacity up to 40kg, thanks to the use of the 5-speed "EC" Electronic Evaporator Fans, which manage temperatures from -40° to +85°C, Scroll compressors and one-speed condenser fan. With climate class 5, it guarantees excellent performance up to 40°C ambient.

2 types of display available:

4.3' display with capacitive screen, white LED bar to follow the progress of the cycle in progress even from a distance.

10' display with capacitive screen, RGB colour LED bar to follow the progress of the cycle in progress even from a distance.

Both displays are equipped with:

- Acoustic signal with adjustable intensity and fixed tone.
- Dashboard customizable with the cycles most used by the customer.
- Ability to customize and/or create new cycles
- Library with all cycles made by the customer and by Irinox

Connectivity

FreshCloud® is Irinox's IOT technology that allows you to control and interact with MultiFresh® Next at any time via an APP.

The functions included in the application are:

- Remote monitoring of the cycle in progress: connection status, cell temperature, core temperature, kitchen and machine name, cycle ID in progress, cycle and phase progress.
- Remote parameter modification (ventilation, cabinet temperature, core probe temperature, humidity level, phase duration)
- Machine status monitoring: connection status, machine ID, laboratory name, serial number, door status, Sanigen level.
- Push notification system
- Usage statistics viewing
- Haccp report download.
- Software update.

Optional

- Double MultiRack for GN 1/1 trays replacing the Standard MultiRack
- Double MultiRack for GN 1/1 trays in addition to the Standard MultiRack
- MultiRack with pastry tray setup
- Sanigen® (Irinox patented sanitization system).
- Water condensation (available only for Turbo performance)
- WIFI printer with 1300 thermal label roll
- Door opening on the right with hinges on the right
- Adjustable lowered feet H = 60-80mm
- 4 wheels, 2 of which with brake.
- Pair of additional GN 2/1 or GN 1/1 or 600x400 mm slides
- Vacuum probe
- Special voltages on request
- Ethernet board
- Base support for stacking 2 MF Next SL
- Base support for stacking an oven
- Reinforced support surface in 1.5 mm thick stainless steel to support an oven or another blast chiller.
- Packing in HT wooden case.

Product warranty

- 2 years from the date of installation, after sending the installation report, on the parts (see warranty condition).

Item No.:

Qty.:

Project:

MULTIFRESH® NEXT SL

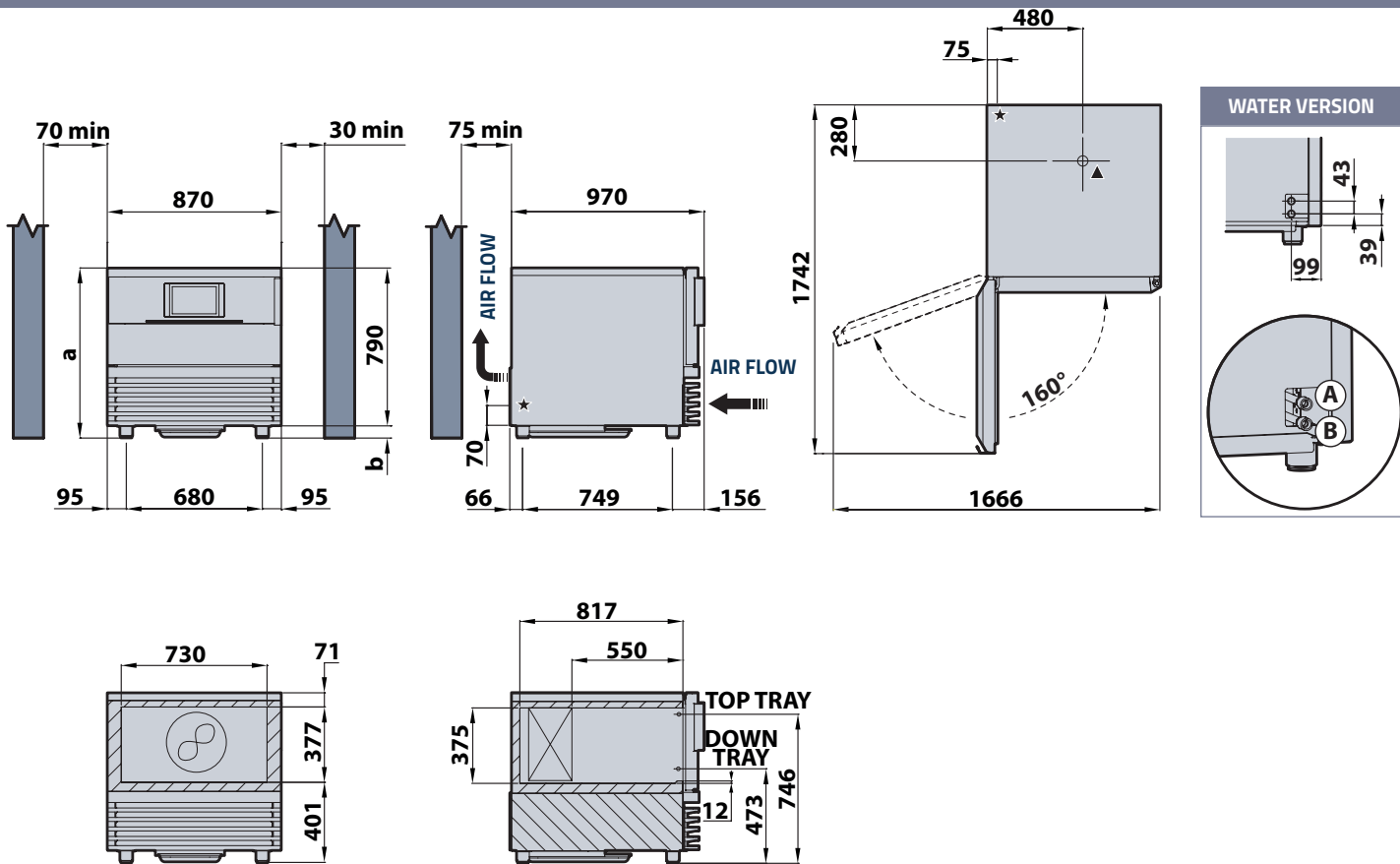

HEIGHT

		HEIGHT (a)	ADJUSTABLE FEET (b)
Standard feet	mm	870 - 905	80 ÷ 115
Lowered feet option	mm	850 - 870	60 ÷ 80
Castors option	mm	888	155

Measures in millimetres

- ★ Main power cable
- ▲ Water drainage corrugated hose $\varnothing 32\text{mm}$
- Ⓐ Water outlet
- Ⓑ Water inlet

ENERGY CONSUMPTION ACCORDING TO EN 17032

Model	MF_NEXT_SL (230V-1N+PE 50Hz)			
Type of product	Blast chiller / Blast freezer			
Performance	TURBO			
Yield per cycle	kg	25		
Energy consumption Blast chilling cycle (STRONG +3 °C)	kWh/kg	0,077		
Energy consumption Blast freezing cycle (STRONG -18 °C)	kWh/kg	0,234		
Blast chilling cycle from/to +65 °C / +10 °C	min	78		
Blast freezing cycle from/to +65 °C / -18 °C	min	270		

Item No.:

Qty.:

Project:

COMMON TECHNICAL DATA

VERSION		AIR CONDENSATION	WATER CONDENSATION
LOW TEMPERATURE COOKING power	W		900
LOW TEMPERATURE COOKING absorption	A		4.6
Water inlet/outlet connections	NPTf	-	3/4"
Maximum water consumption (inlet temp. +30°C / outlet temp. +35°)	l/h	-	864
MIN/MAX inlet water temperature (cooled water)	°C	-	+10 / +22 °C
MIN/MAX inlet water temperature (tower water)	°C	-	+23 / +35 °C
Coolant type	-	R290	
Nominal coolant quantity	kg	0.15	0.11
Dimensions (WIDTH x DEPTH)	mm	870 x 970	
Cell internal dimensions (WIDTH x DEPTH x HEIGHT)	mm	730 x 550 x 375	
Cabinet weight	kg	140	-

VOLTAGE	220-240V 1ph+N+PE 50Hz		
		AIR CONDENSATION	WATER CONDENSATION
Performance		TURBO	
Power rating	W	1600	1580
Full load amps (FLA)	A	7.7	7.5
Main power cable	mm ²	3G1.5	3G1.5
Cooling power (-10/+40°C; Tsuct +20°C; Subcooling 0°C)	W	3360	3360
MAX Condensing power (-5/+45°C; Tsuct +20°C; Subcooling 0°C)	W	5340	5340
Minimum air exchange	m ³ /h	1200	-
Climate class	-	5 (40°C)	5 (40°C)

VOLTAGE	220-240V 1ph+N+PE 60Hz / 220-240 2ph+PE 60Hz		
		AIR CONDENSATION	WATER CONDENSATION
Performance		TURBO	
Power rating	W	1960	1940
Full load amps (FLA)	A	9.5	9.4
Main power cable	mm ²	3G1.5	3G1.5
Cooling power (-10/+40°C; Tsuct +20°C; Subcooling 0°C)	W	4032	4032
MAX Condensing power (-5/+45°C; Tsuct +20°C; Subcooling 0°C)	W	6408	6408
Minimum air exchange	m ³ /h	1320	-
Climate class	-	5 (40°C)	5 (40°C)

VOLTAGE	230V 1ph+N+PE 60Hz / 230- 2ph+PE 60Hz		
		AIR CONDENSATION	
Performance		TURBO	
Power rating	W	1960	
Full load amps (FLA)	A	9.5	
Main power cable	mm ²	3G1.5	
Cooling power (-10/+40°C; Tsuct +20°C; Subcooling 0°C)	W	4032	
MAX Condensing power (-5/+45°C; Tsuct +20°C; Subcooling 0°C)	W	6408	
Minimum air exchange	m ³ /h	1320	
Climate class	-	5 (40°C)	

INSTALLATION

The blast chiller must be installed following and complying with what is stated in the appropriate installation manual. The contents of the manual must be carefully followed to ensure correct operation and to protect the user's rights under the warranty. Continuous product development may require changes to specifications without notice.

Irinex SpA

Headquarter: Via Madonna di Loreto, 6/B - 31020 - Corbanese di Tarzo (TV) Italy

Productive Site: Via Mattei, 20 - 31029 - Vittorio Veneto (TV) Italy

Tel. +39 0438 2020 | irinox@irinox.com | www.irinoxprofessional.com

