

MF 85.2 PLUS

REACH IN Blast Chiller and Shock Freezer



MultiFresh®: the multi-function assistant that will organize your production and processes with flexibility 24 hours a day.

MultiFresh is the first and only machine in the world that can run operating cycles with temperatures from 85°C to -40°C preserving its consistency, moisture content, and nutritional properties.

Multifunction 7" touchscreen display, product specific cycles, wide range of options, customization of all the parameters for each cycle.

Capacity

Number of trays: 27 x GN2/1 or 600x400 (H= 20 mm)

Number of trays: 18 x GN2/1 or 600x400 (H= 40 mm)

Number of trays: 13 x GN2/1 or 600x400 (H= 65 mm)

Yield

Yield for blast chilling cycle (90/+3°C) Kg 85

Yield for shock freezing cycle (90/-18°C) Kg 85

Product Warranty Protection

- 2 years from the date of installation, after sending the installation report, on the parts (see warranty condition)

Certification



Standard Construction Features

- IRINOX BALANCE SYSTEM®: the perfect size of the main refrigerator components (condenser, evaporator, compressor and fan).
- Self-contained, air-cooled condensing unit.
- Maximum cleanliness and hygiene due to rounded corners and components situated in the chamber so that they can be accessed and cleaned easily.
- Soft closing magnetic door closure with a high/low temperature resistant gasket.
- Irinox patented system of probe's magnetic attachment to the door makes it easily stored and accessible.
- MultiSensor® 5 point probe for perfect temperature control.
- Automatic switch from manual mode (timed) to automatic mode (with probe); MultiFresh® senses if the probe has been inserted or not.
- Manual defrosting at the end of the day (not during the work cycles).
- Wireless data transfer (HACCP control software).
- Door hinged Left.
- 4 adjustable feet H 115-165 mm
- 15 pairs of guides.

Unique Design and Performance Features

- PLUS VERSION: cold and hot functions included : BLAST CHILLING & SHOCK FREEZING + THAWING, HOLDING, CHOCOLATE, REGENERATION, PASTEURIZATION, PROOFING, LOW TEMPERATURE COOKING.
- SANIGEN®: 24/7 sanitification (Irinox patented sanitification system, sanitizes every part of the chamber).
- MULTIRACK®: an adjustable tray holder, which allows operators to double the number of trays loaded in each model.
- MultiFresh®'s touch screen also works when you are using kitchen gloves.
- Refrigerant gas R452A.

Option and Accessories

- Door hinged Right
- 4 Casters (2 with locks)
- Sous-vide core probe
- Additional core probe
- Additional pairs of guides
- Cityline Water Condensation unit
- Remote Condensation unit
- Wifi MyA connection
- Ethernet Board
- FreshCloud - The Irinox Cool Connection (EU countries only)
- Double MultiRack (for GN 1/1 trays) at the place or in addition of the standard MultiRack

Cabinet

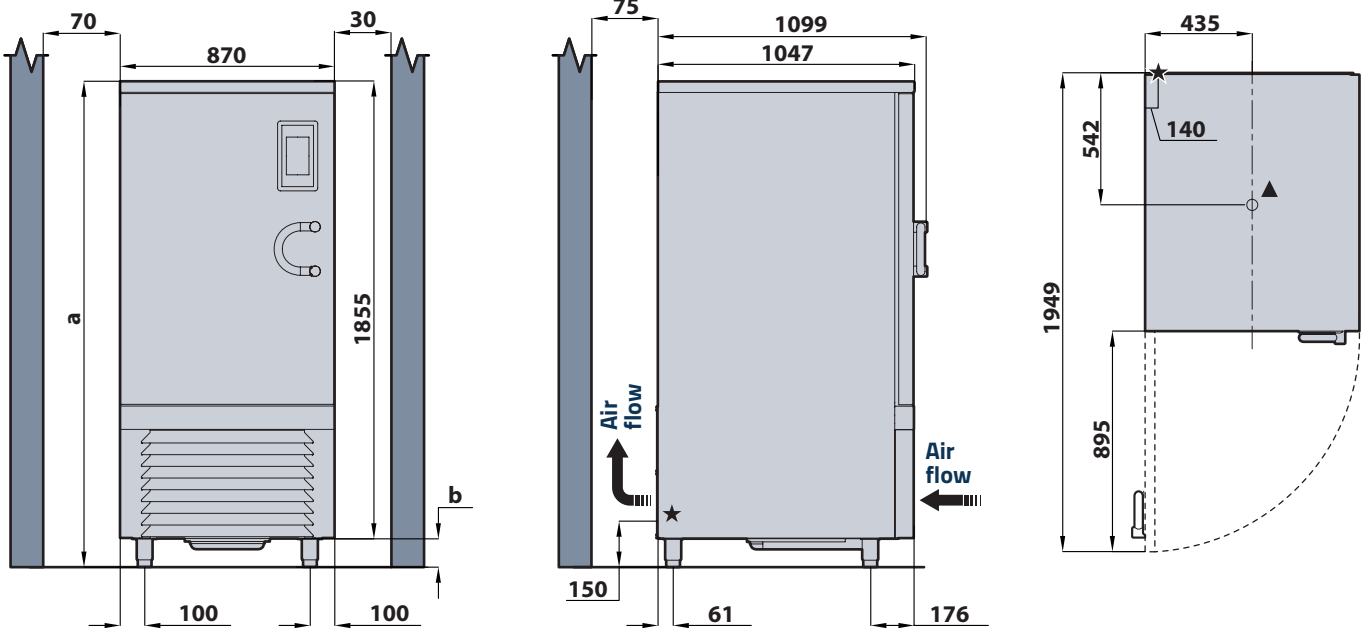

- ★ Main power cable
- ▲ Drain pipe \varnothing 31

	Cabinet
Width	870 mm
Depth	1099 mm
Height w/legs not extended	1970 mm
Height w/casters	2010 mm
Weight	305 Kg

Electric Data / Power Requirements	
Electric Supply	400V 3N+PE 50Hz
Full load amps	A 13,50
Total Rating (FLI)	kW 6,20
Main power cable	4G2.5 + 10x1.5

Key Refrigeration System Data	
Compressor Rating (HP)	5,5
Refrigeration Yield (-10/40°C)	10853
Condenser rating (-10/40°C)	15842
Refrigeration Type	R452A
Maximum Ambient Air Temperature	°C 32

INSTALLATION

A detailed installation manual is provided. It must be carefully followed to ensure proper operation and to protect your rights under the warranty.

Continued product development may necessitate specification changes without notice.

Irinox SpA

Headquarter: Via Madonna di Loreto, 6/B - 31020 - Corbanese di Tarzo (TV) Italy

Productive Site: Via Mattei, 20 - 31029 - Vittorio Veneto (TV) Italy

Tel. +39 0438 2020 | irinox@irinox.com | www.irinoxprofessional.com